

Title:

Beam Steering Engine for a Two-Dimensional Microphone Array

Local seminar 1

Committee members:

Prof. W.C. Miller

Prof. G.H. Jullien

Prof. M. Ahmadi

Prof. N. Zamani

Student:

Seyed Mohammad Makki

University of Windsor

Contents:

1. Abstract	3
2. Major idea	4
3. Benefits of using a microphone array	6
4. Evaluating Speech Enhancement	7
5. Major criteria	8
6. Problems and Solutions	9
7. Scope of the circuit architecture	18
8. Subsequent work	19
9. Important papers	19

1. Abstract

Multi-microphone noise reduction techniques for hearing aid applications go together with the use of small-sized arrays. Considerable noise reduction can be achieved with such arrays but at the expense of an increased sensitivity to model errors or priori assumptions. We introduce a fast and low-complexity VLSI architecture as the engine to steer the sound through a two-dimensional miniature-sized microphone array. An intelligent hardware comes up with the direction of arrival and converges to the best frequency performance case. Therefore, the problem of low efficiency beamformation due to dealing with wideband audio signals will be resolved. This architecture is programmable for different array sizes. Providing different modes of operation in the design facilitates the usage of the device for the user.

2. Major idea

- a) Using appropriate delays for the channels
- b) Signals entering from DOA will be in-phase
- c) Signals entering from other directions will be out of phase
- d) Adding the collected delayed signals

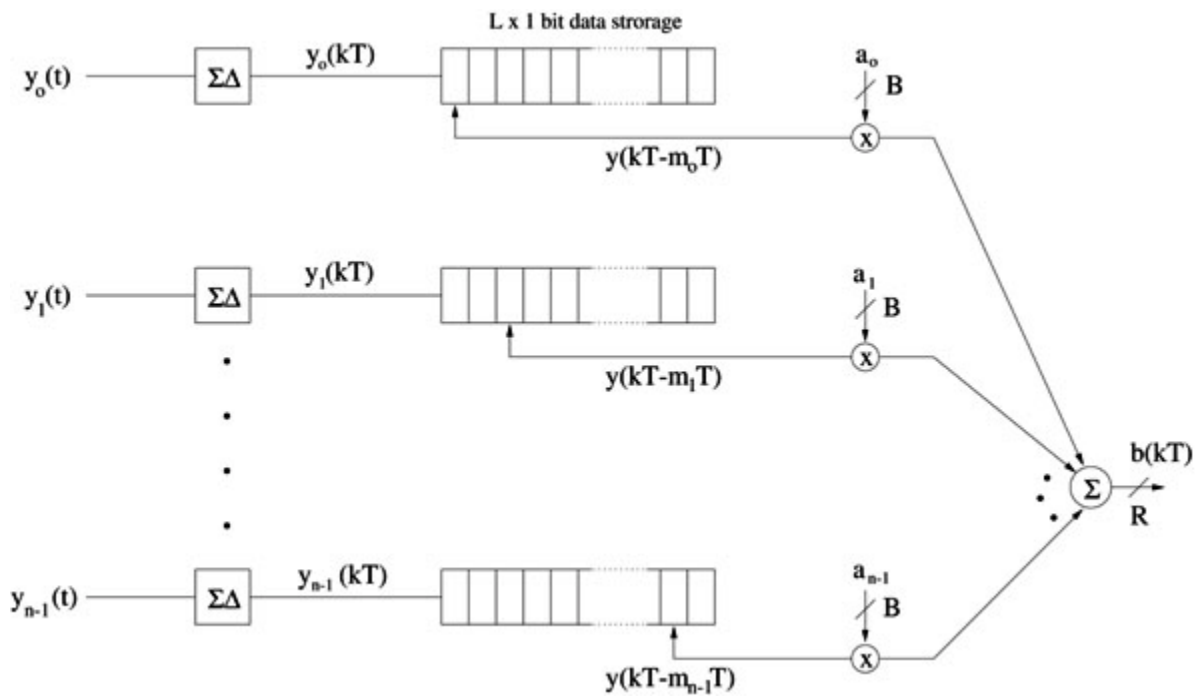

Fig.1: Digital Delay-and-Sum beamformer

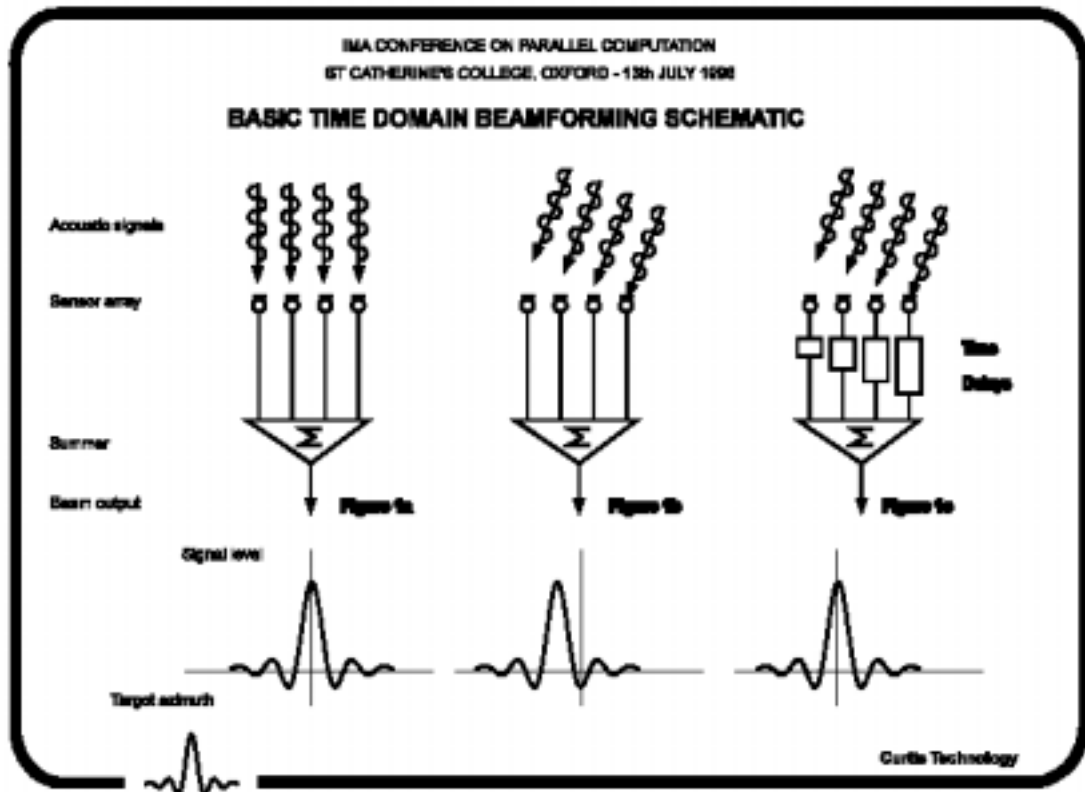

Fig. 2: Beamformation by Delay-and-Sum

3. Benefits of using a microphone array

- **Directionality**
- **Attenuating interference**
- **Background noise elimination and obtaining much higher SNR**
- **Less sensitivity to reverberation**
- **Blind source localization of acoustic sources**
- **Acoustic tracking facility**

4. Evaluating speech enhancement

1. Subjective criteria

a) Intelligibility

- Diagnostic Rhyme Test (DRT)
- Modified Rhyme Test (MRT)
- Phonetically Balanced Word List (PB)

b) Speech quality

- Diagnostic Acceptability Measure (DAM)
- Mean Opinion Score (MOS)
- Degradation Mean Opinion Score (DMOS)

2. Objective criteria

a) Signal-to-Noise Ratio (SNR)

$$\text{SNR}(x,y) = 10 \log_{10} \left(\frac{\sum_{n=1}^N |x(n)|^2}{\sum_{n=1}^N |x(n) - y(n)|^2} \right)$$

$$\text{peak SNR}(x,y) = 10 \log_{10} \left(\frac{\sum_{k=1}^K |y(n_{max},k)|^2 - \sum_{k=1}^K |y(n_{min},k)|^2}{\sum_{k=1}^K |y(n_{min},k)|^2} \right)$$

b) Segmental Signal-to-Noise Ratio (SSNR)

$$\text{SSNR}(x,y) = \frac{1}{N} \sum_{n=1}^N 10 \log_{10} \left(\sum_{k=1}^K \frac{|x(n,k)|^2}{|x(n,k) - y(n,k)|^2} \right)$$

c) Bark Spectral Distortion (BSD)

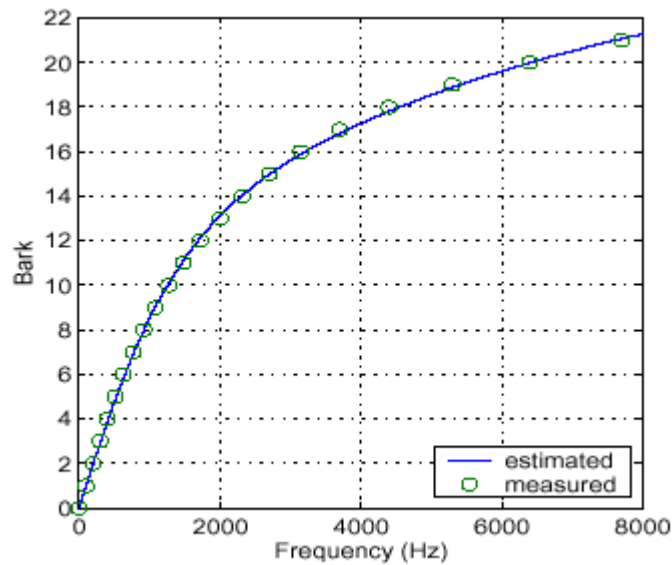

$$z = 13 \operatorname{atan}(.00076f) + 3.5 \operatorname{atan}\left(\frac{f}{7500}\right)^2$$

5. Major criteria

- **Low power consumption**
- **Low complexity (reasonable area)**
- **Reasonable speed**

6. Problems and Solutions:

- **Inappropriate array dimensions:**

The dimensions of the array must be in the range of some centimeters not millimeters, which is the case for the available MEMS microphone array. Adding delays cannot solve this problem.

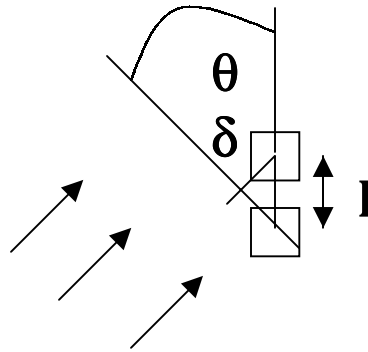

$$t_0 = \frac{l \cdot \sin \theta}{c_s} = \frac{l \cdot \sin \theta}{f \cdot \lambda} = \frac{2 \cdot \pi \cdot l \cdot \sin \theta}{\lambda \cdot \omega}$$

Target:

$$\frac{K}{2} \cos \omega \cdot (t - \delta) + \frac{K}{2} \cos \omega \cdot (t - \delta) = K \cos \omega \cdot (t - \delta)$$

Jammer:

$$\frac{K}{2} \cos \omega \cdot (t - \delta) + \frac{K}{2} \cos \omega \cdot (t - t_0 - \delta) = \frac{K}{2} \cos \omega \cdot (t - \delta) + \frac{K}{2} \cos \omega \cdot (t - \frac{2 \cdot \pi \cdot l \cdot \sin \theta}{\lambda \cdot \omega} - \delta)$$

$$K=1$$

$$\delta=0$$

$$\theta=90$$

$$l=2.5\text{mm}$$

$$f=20\text{KHz}$$

$$\lambda=C_s/f=340/20\text{KHz}=17\text{mm}$$

$$t_0=l/C_s=2.5\text{mm}/340=7.35\mu\text{s}$$

$$\text{Target: } \cos \omega.t$$

$$\text{Jammer: } 0.956\cos \omega.t$$

$$f=20$$

$$\text{Target: } \cos \omega.t$$

$$\text{Jammer: } 0.999\cos \omega.t$$

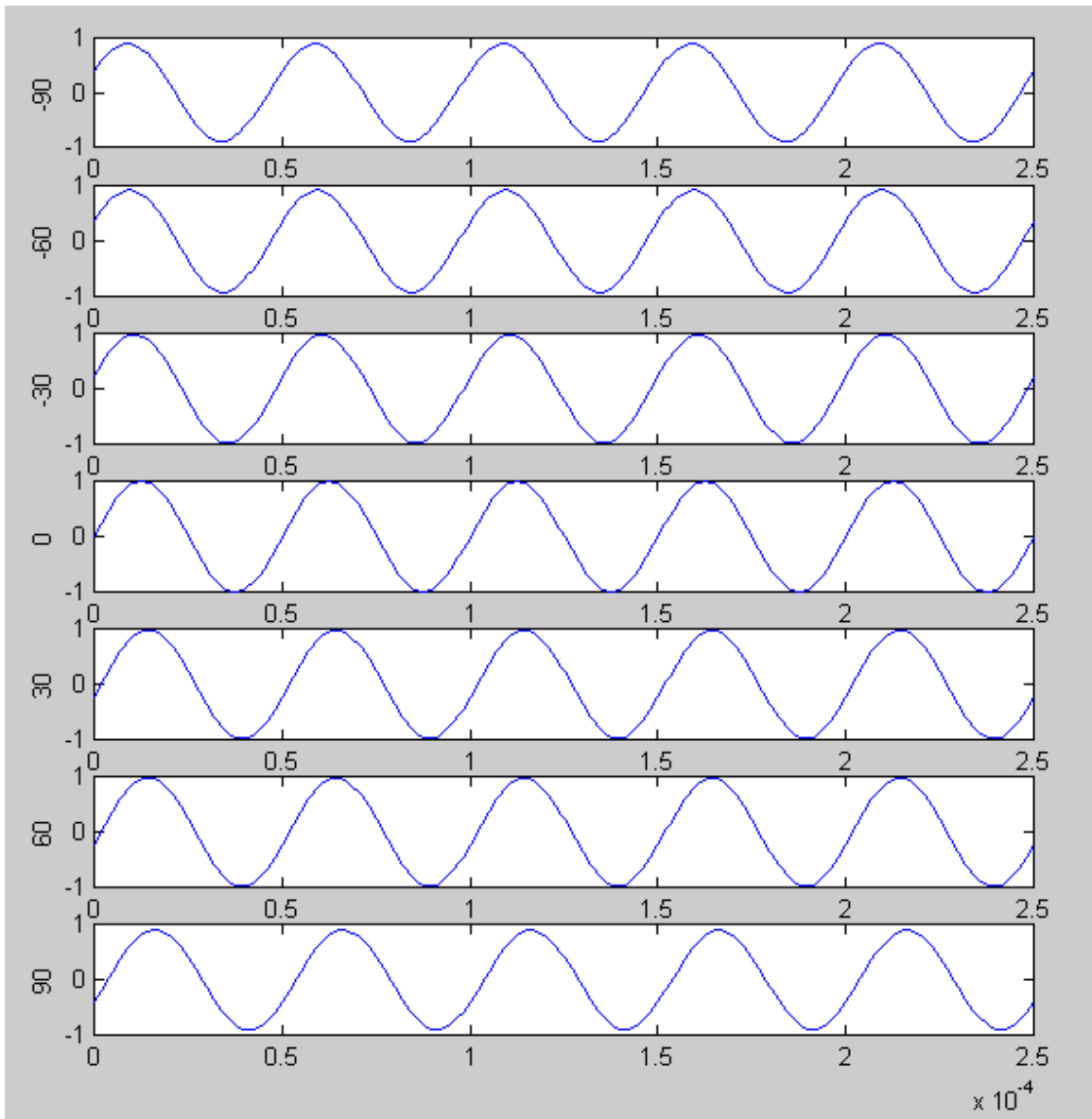

Fig.4: Directions of Arrival

Solution to the problem:

$$\omega \cdot t_0 = \pi$$

$$2 \cdot \pi \cdot f \cdot t_0 = \pi$$

$$f = 1 / (2 \cdot t_0) = 1 / (2 \times 7.35 \mu\text{s}) = 68 \text{ KHz}$$

Target: $\cos \omega \cdot t$

Jammer: 0

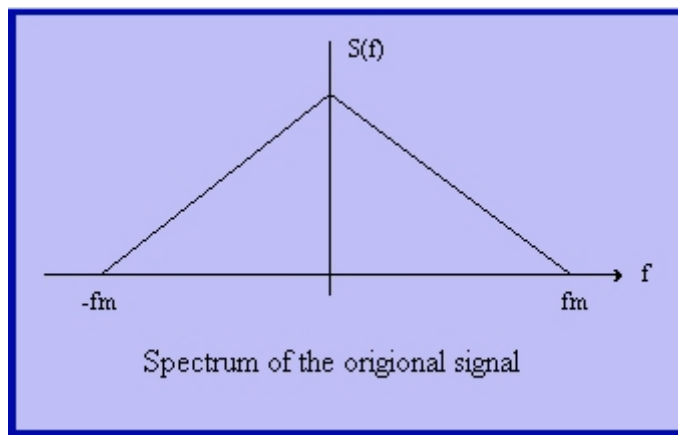

(a)

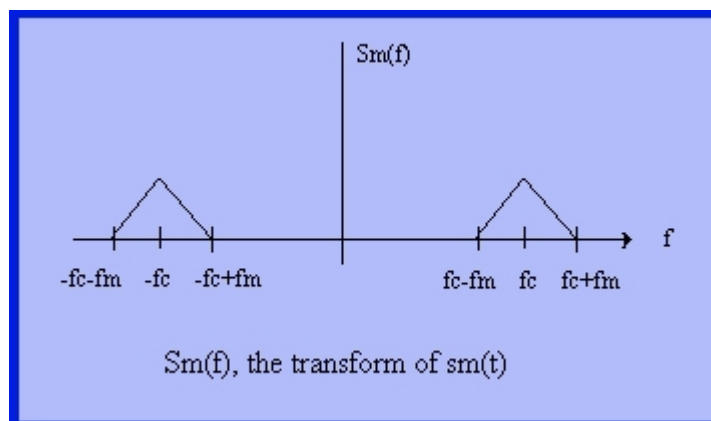

(b)

Fig. 5: The spectrum in frequency conversion

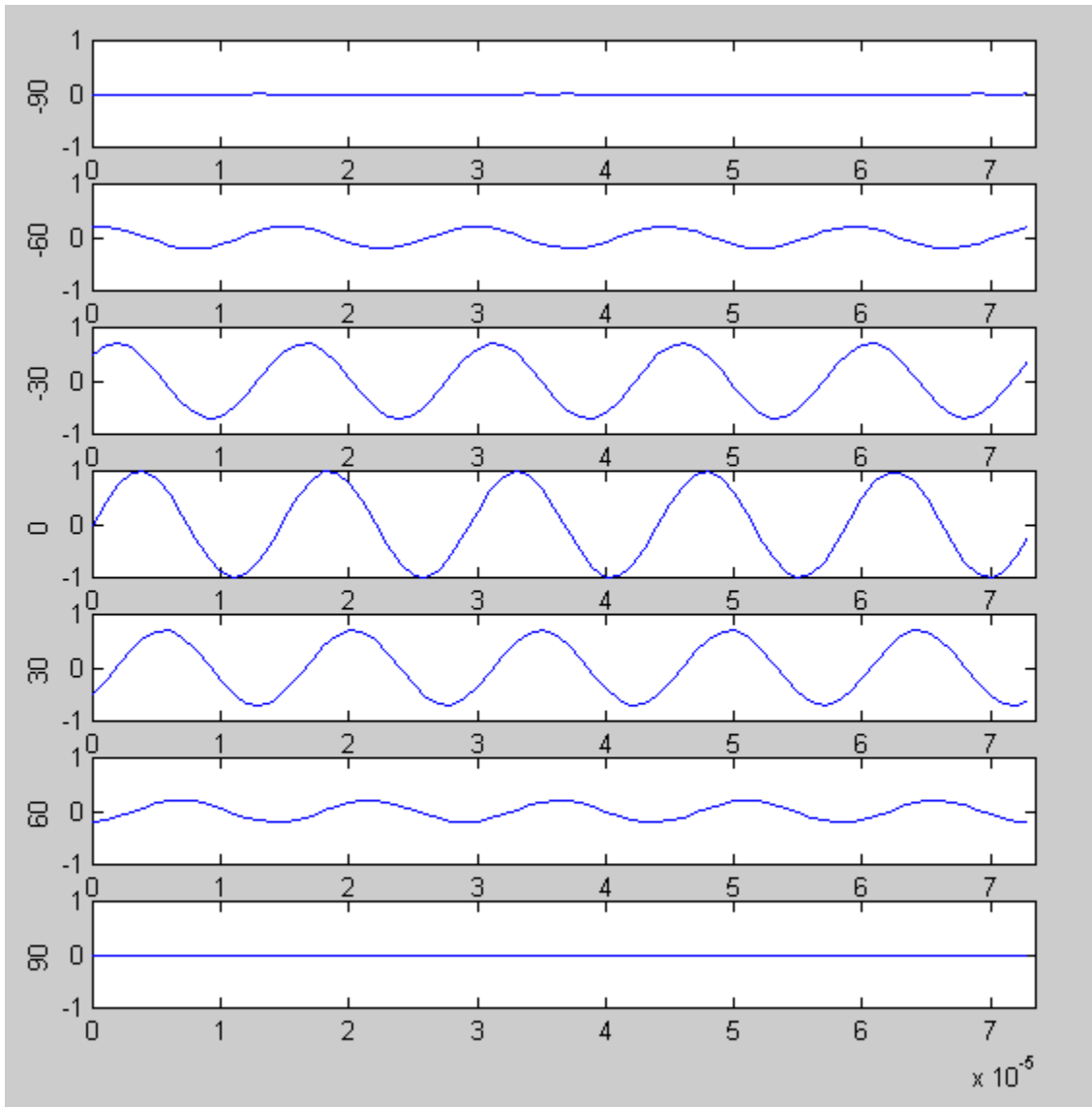

Fig.6: Directions of Arrival after improvement

- **Sharpness of beamwidth:**
Beamwidth must be reasonably low.

Improvements to Delay-and-Sum structure:

a) Delay-and-Sum

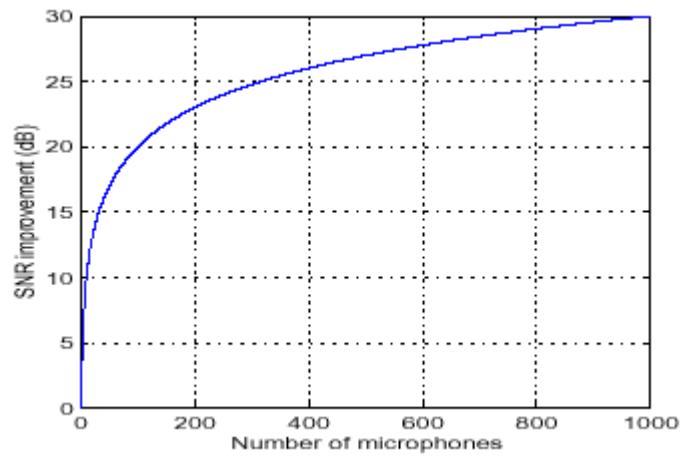

Fig.7

b) Delay-Weight-and-Sum

- **Superdirective arrays**

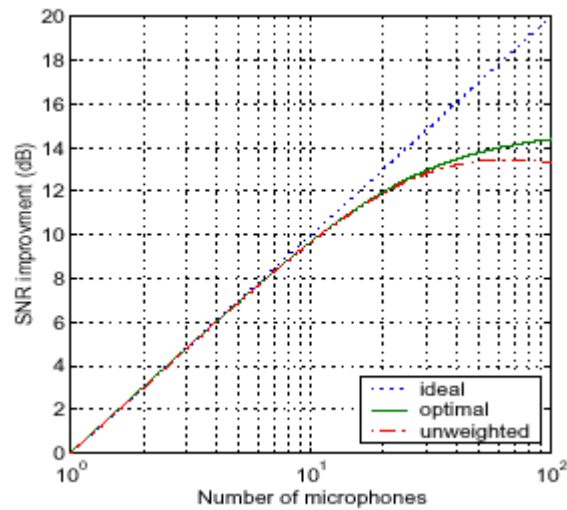

Fig.8

c) Delay-Filter-and-Sum

- Generalized Side-lobe Canceller

Example: Multi-channel Wiener Filter

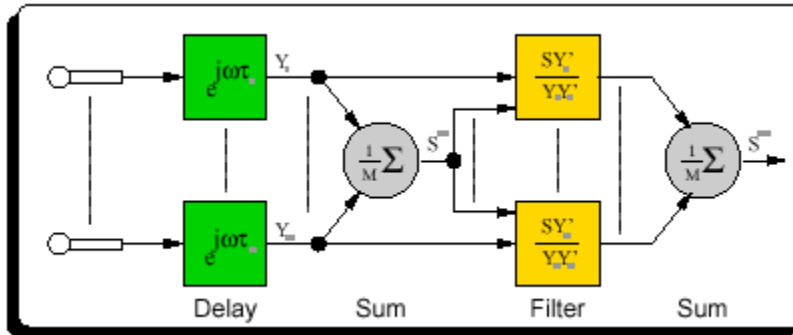

Fig.9: Wiener Filter-and-Sum-Filter

- Dealing with wideband signals:

Beamsteering algorithms are mostly suitable for narrowband signals while sound with the wide domain of frequencies of 20Hz-20kHz is wideband. Using a filter bank and applying the beamsteering algorithm to all of the frequency bands is one of the solutions and some researchers have tried it. But it makes the circuit very complicated and detailed that contradicts with low power consumption assumption.

Solution to the problem:

The idea of frequency conversion can be utilized to convert the base-band wideband signal to a narrowband signal. Thus the

problem will be solved. For more accuracy, different rows of rectangular sensor array can be used separately for different frequencies and the system will converge to the best frequency for the optimum performance.

- **Cocktail-party phenomenon:**

One of the most prevalent complaints of ordinary hearing-aid wearers is the problem of weak intelligibility in noisy environments as a cocktail party. As far as there are many sound sources, intelligibility is weak.

- **Reverberation:**

Convolutional distortion of audio signals is called reverberation. The echo of the sound in closed areas is one of the well-known instances of reverberation. Reverberation may be the primary source of interference in an auditorium or concert hall.

Solution to the problems:

By restricting the area to be scanned to the look direction this problem can be considerably resolved. But in this case, we will need to have different modes of operation and possibly a training scheme.

- **No access to chip after installation:**

We need to have access to chip after installation for calibration, probable training and preprogramming for different sized arrays. As far as this is a CIC (Completely In the Canal) hearing aid, there is no access to it after installation.

- **Binaural hearing:**

If both of the ears are taking advantage of microphone array hearing aids, they need to be in accordance with each other. For CIC hearing aids, it is not possible to have an internal wiring between two ears and it is nasty to have an external wiring to frustrate the advantage of using CIC hearing aids.

Solution to the problems:

Having access to chip after installation and communication between two hearing aids is feasible by means of a wireless link.

7. Scope of the circuit architecture

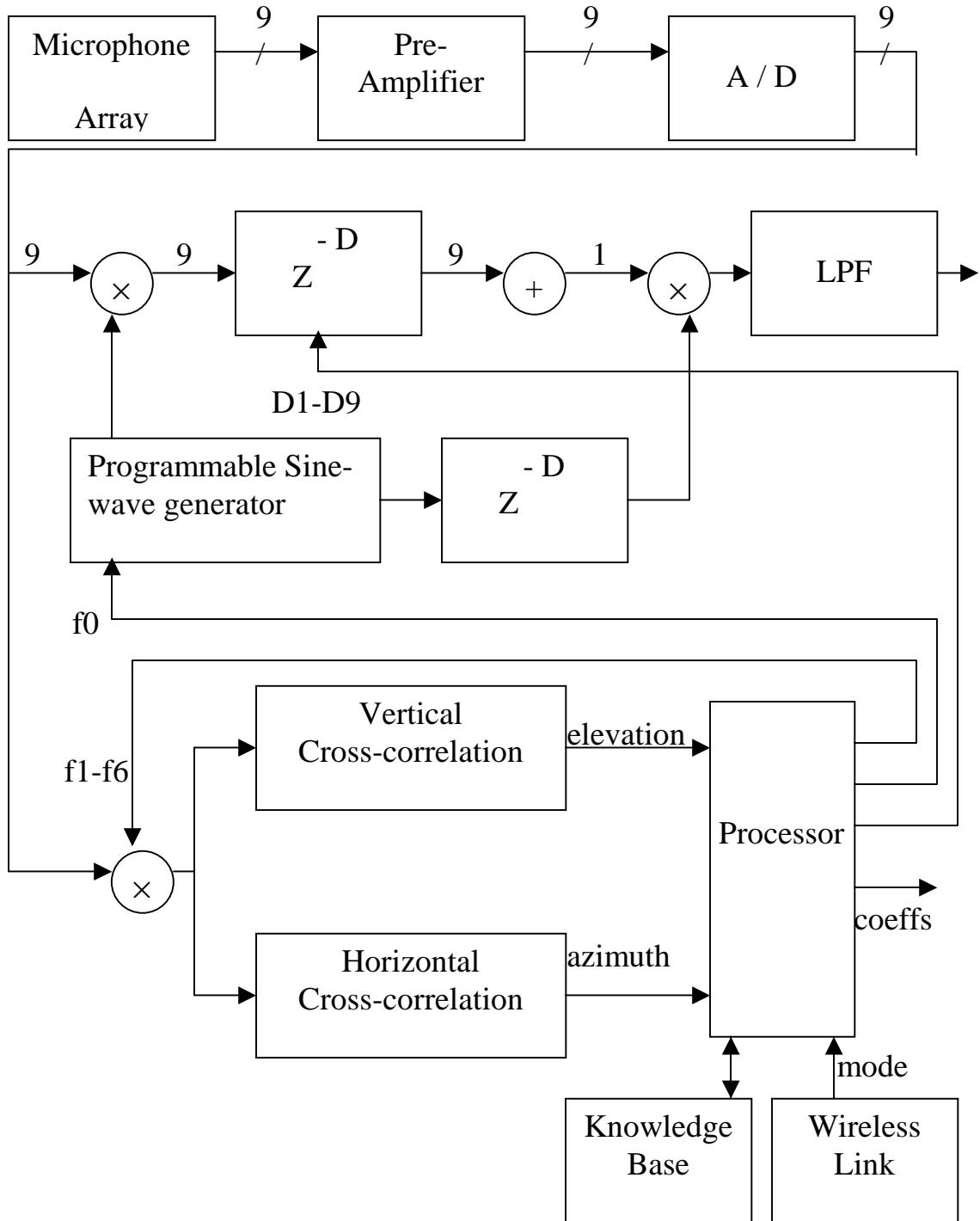

8. Subsequent work

- Finalizing the DSP system
- VLSI implementation
- Fabrication
- Test

9. Important Papers

- Bernard Widrow, “A Microphone Array for Hearing Aids,” Adaptive Systems for Signal Processing, Communications and Control Symposium 2000, pp. 7-11.
- M. Kompis, P. Feuz, G. Valentini and M. Pelizzone, “A Combined Fixed/Adaptive Beamforming Noise-Reduction System for Hearing Aids,” Proceedings of the 20th Annual International Conference of the IEEE Engineering in Medicine and Biology Society, Vol. 20, No. 6, 1998.